

ITEM NO.	PART NUMBER	DESCRIPTION	QTY.
1	56"X82" TOP	56"X82" UTILITY VAULT TOP	1
2	4' X 6' HATCH	4' X 6' ACCESS HATCH	2
3	RR-0002	3/4" JACK NUT PRECAST INSERT	6
4	RR-0034-5	3/4" X 5" JACK SCREW / 5/8" HEX HEAD	6

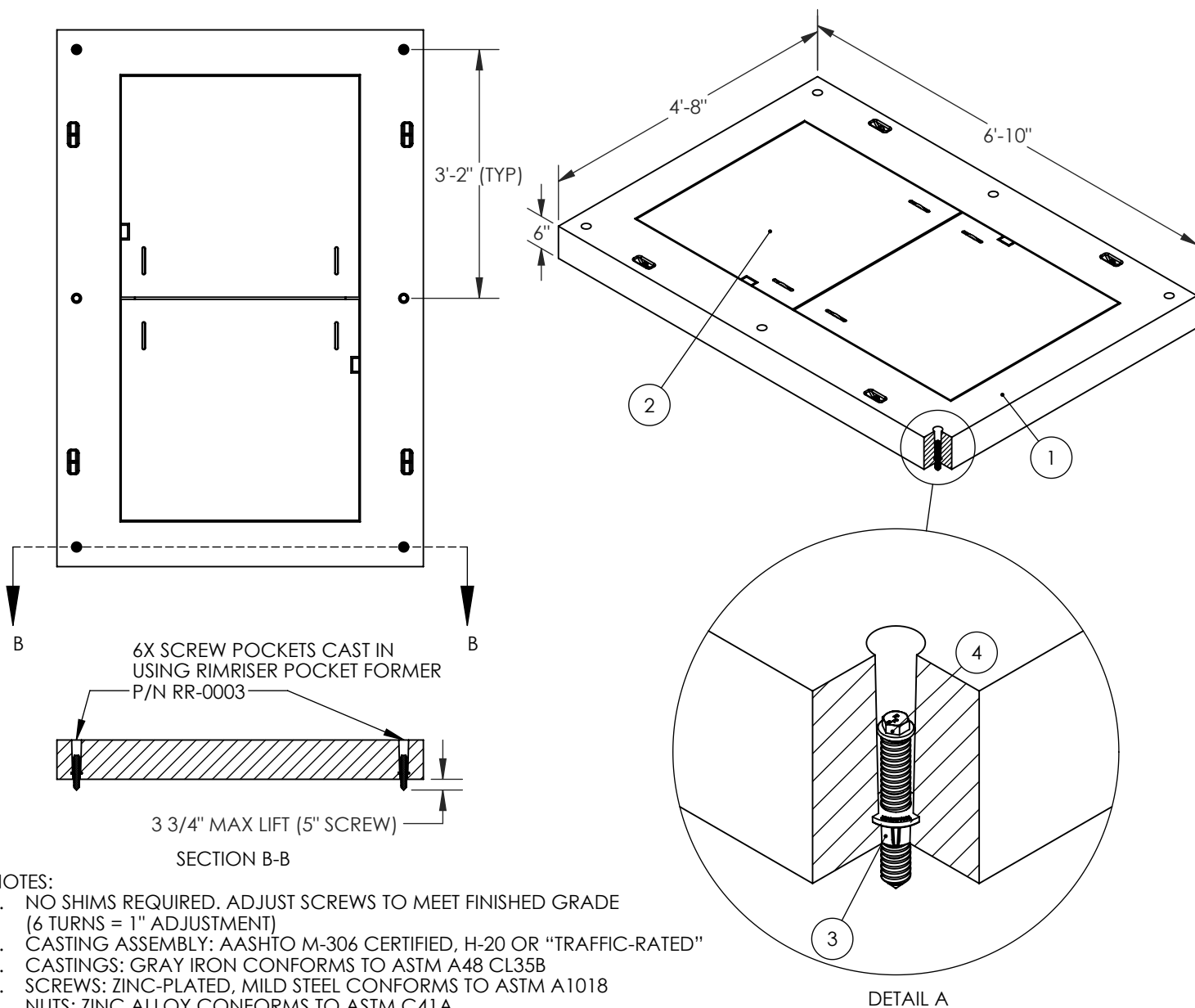

NOTES:

1. NO SHIMS REQUIRED. ADJUST SCREWS TO MEET FINISHED GRADE (6 TURNS = 1" ADJUSTMENT)
2. CASTING ASSEMBLY: AASHTO M-306 CERTIFIED, H-20 OR "TRAFFIC-RATED"
3. CASTINGS: GRAY IRON CONFORMS TO ASTM A48 CL35B
4. SCREWS: ZINC-PLATED, MILD STEEL CONFORMS TO ASTM A1018
5. NUTS: ZINC ALLOY CONFORMS TO ASTM C41A
6. PRECAST STRUCTURE: DESIGN AND MATERIALS CONFORM TO ASTM SPECIFICATIONS
7. GENERALLY, FILL AND PACK GAP BETWEEN PRECAST TOP AND SUPPORTING BASE WITH NON-SHRINK GROUT AND FINISH SMOOTH/FLUSH WITH INTERIOR AND EXTERIOR OF ADJOINING SURFACES. REFER TO LOCAL SPECIFICATIONS.
8. U.S. AND FOREIGN PATENTS PENDING. ALL PARTS MADE IN USA.
9. USE ONLY GENUINE RIMRISER PARTS.

RIMRISER RESERVES THE RIGHT TO MODIFY OR CHANGE PRODUCT DESIGN OR CONSTRUCTION WITHOUT PRIOR NOTICE AND WITHOUT INCURRING OBLIGATION TO MAKE SIMILAR CHANGES AND MODIFICATIONS TO PRODUCTS PREVIOUSLY OR SUBSEQUENTLY SOLD. SEE YOUR RIMRISER REPRESENTATIVE FOR ANY CLARIFICATION. DIMENSIONS ARE SUBJECT TO MANUFACTURING TOLERANCES. TEL: (360) 833-2277 RIMRISER.COM

REV.	DATE	APPROVED BY	STANDARD DETAIL			NAME	DATE
			TITLE	DRAWN BY	DATE	SRH	07/20/2021
B	08/06/21	AMB	56"X82" UTILITY VAULT TOP STANDARD DETAIL	APPROVED BY	AMB	07/20/2021	
				DETAIL NO.	SD-RR-5682 TOP		
			SIZE	A		NOT TO SCALE	REV. B

RIMRISER™
315 N GRAND BLVD, SUITE 100
VANCOUVER, WA 98661